

# AT2-R556, AT2-R557

PROFIBUS, RTB, 16 Points, Sink/Source Input 24Vdc  
Output, 8 Points, Relay, 250Vac/2A, 24Vdc/2A

FnIO A-Series, PROFIBUS

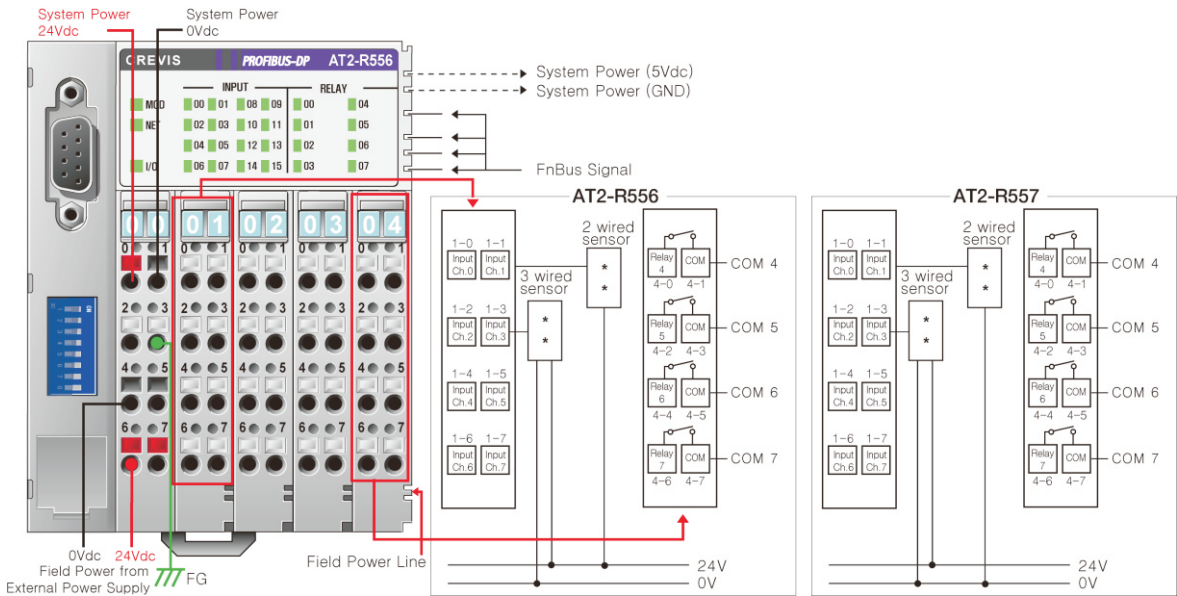

Item	AT2-R556		AT2-R557				
<b>Interface Specification</b>							
Number of Input	16 Points, Sink Type(GND Common internally shorted)		16 Points, Source Type(24V Power internally shorted)				
Indicates	1 LED/1Point						
Input Voltage	Nominal 24Vdc, 11~28.8Vdc		Nominal 0Vdc, 11~28.8Vdc				
Max. Off-state Voltage	5Vdc						
Min. On-state Voltage	9Vdc						
Input Signal Delay	<0.5msec						
Input Impedance	About 5.4KΩ						
<b>Interface Specification</b>							
Number of Output	8 Points						
Indicates	1 LED/1Point						
Relay Type	From Am Normally Open / Single Pole, Single Throw						
Output Rating	2A@5~28.8Vdc / 0.8A@48Vdc 0.5A@110Vdc / 2A@250Vdc						
Min. Load	100uA, 100mVdc/Point						
Max. On-State Voltage	0.5V@2.0A, Resistive Load, 24Vdc						
Output Delay Time	On to Off : Max. 10ms / Off to On : Max. 10ms						
Initial Contact Resistance	30mΩ						
Expected Contact Life	300K Cycle Resistive, 100K Cycle Inductive						
Common Type	1 Point / 1 COM (Single Common)						
Isolation	I/O Logic : Relay Coil / Contact Isolation 1250 Vrms tested						
<b>General Specification</b>							
Power Dissipation	Max. 50mA @5.0Vdc						
Isolation	Profibus to internal logic : Non-isolation / Internal logic to I/O driver : Isolation						
Field Power	Supply Voltage : 24Vdc nominal / Supply Voltage range : 11~28.8Vdc						
Field Power Current	Max. 6A@24Vdc						
Weight	Max. 340g						
Module Size	83mm x 99mm x 70mm						
Environment Condition	Refer to " Environment Specification"(page : 2-32)						
Pin No.	Description	Pin No.	Description	Pin No.	Description	Pin No.	Description
1-0	Input Channel 0	2-0	Input Channel 8	3-0	Relay Output 0	4-0	Relay Output 4
1-1	Input Channel 1	2-1	Input Channel 9	3-1	COM 0	4-1	COM 4
1-2	Input Channel 2	2-2	Input Channel 10	3-2	Relay Output 1	4-2	Relay Output 5
1-3	Input Channel 3	2-3	Input Channel 11	3-3	COM 1	4-3	COM 5
1-4	Input Channel 4	2-4	Input Channel 12	3-4	Relay Output 2	4-4	Relay Output 6
1-5	Input Channel 5	2-5	Input Channel 13	3-5	COM 2	4-5	COM 6
1-6	Input Channel 6	2-6	Input Channel 14	3-6	Relay Output 3	4-6	Relay Output 7
1-7	Input Channel 7	2-7	Input Channel 15	3-7	COM 3	4-7	COM 7